

INSTALLATION INSTRUCTIONS

JOHN DEERE 892E EXCAVATOR



**Hammond Air Conditioning Ltd.
125 Samnah Cres.
Ingersoll, On.
N5C 3J7
1-800-267-2665
1-888-267-3745 (FAX)**

EVAPORATOR:

The evaporator/heater box mounts against the back wall of the cab above the computer assembly. It will be necessary to trim the center panel above the computer for a proper fit.

1. Remove the following:
 - Seat (retain hardware)
 - Fuse cover (unclip)
 - Center trim panel (retain hardware)
 - Left storage tray (retain hardware)
 - Bottom guards under cab and directly behind (for hose and wiring routing).
2. With the template provided, locate the mounting holes to bolt the evaporator assembly to the back wall of the cab. The four lower holes will be the ones used and the top will extend above the bottom of the window
3. Pilot drill the mounting holes to ¼” diameter and drill through both cab layers and the front wall of the storage compartment, immediately behind the cab.
4. Using a 1 ½” hose saw, enlarge the holes in the storage compartment front wall to allow access to the mounting bolts. Re-drill the cab holes to 3/8” using the smaller holes as guides.
5. Select the appropriate length of bolt to mount the evaporator from the hardware provided. Use a large diameter washer (provided) against the back outside wall of the cab to prevent pull-through and to more easily seal the holes later.
6. Tighten the bolts so that the outside of the cab begins to deform. The evaporator should be solid in place but does not need to be fastened so that the cab wall is deformed to a great degree. Seal the outside holes with silicone to prevent water entry.
7. Install the tray under the evaporator to prevent any condensation from damaging the computer.
8. Using the measurement pattern provided below, trim the center panel to fit around the evaporator unit in place. Do not install until the system has been tested and charged.
9. Connect A/C lines to the evaporator fittings and tar tape all exposed metal that could sweat from condensation.

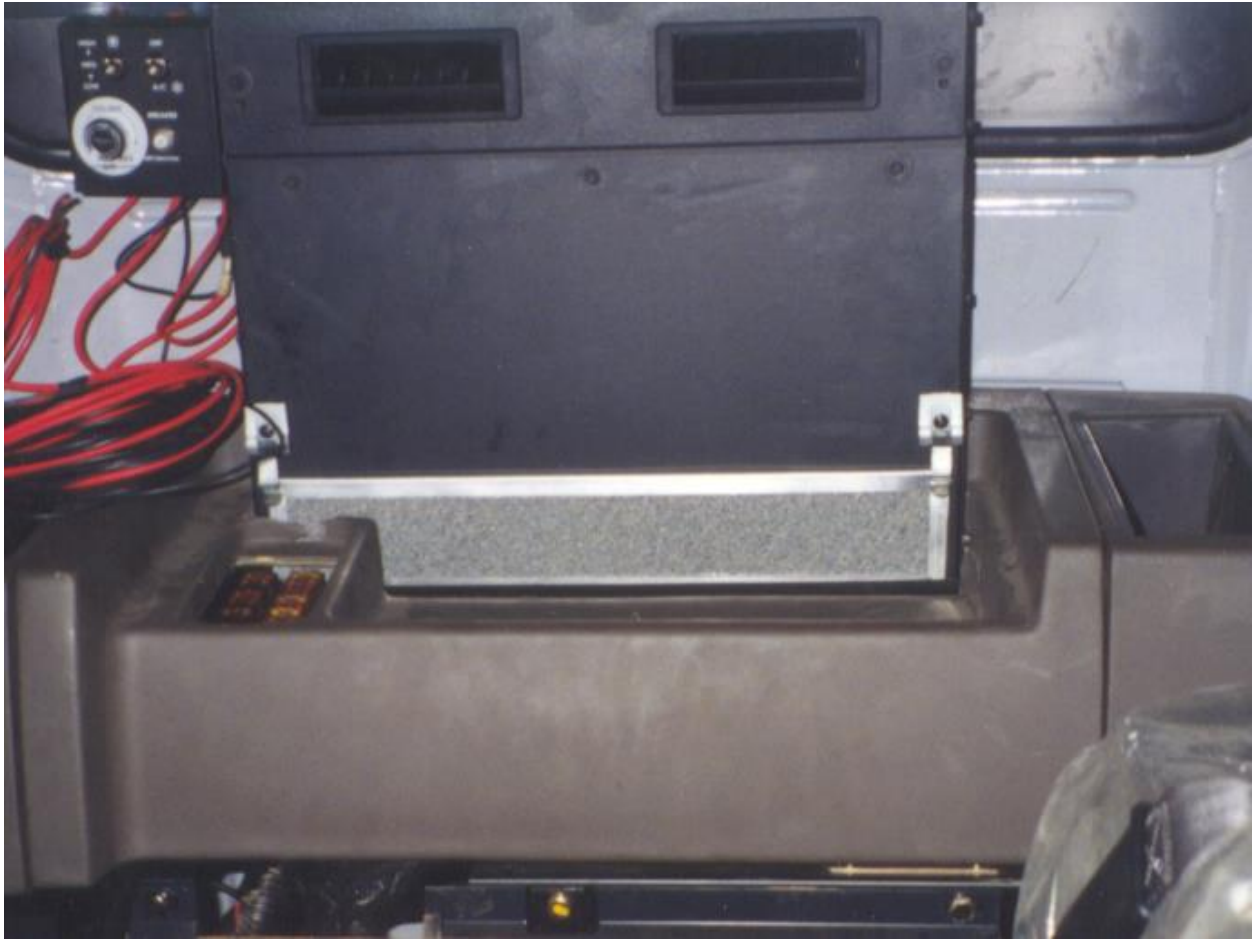

Evaporator in place on back wall of cab. Note that it extends above the lower window line.



Bottom of evaporator showing cut-out in center trim panel.

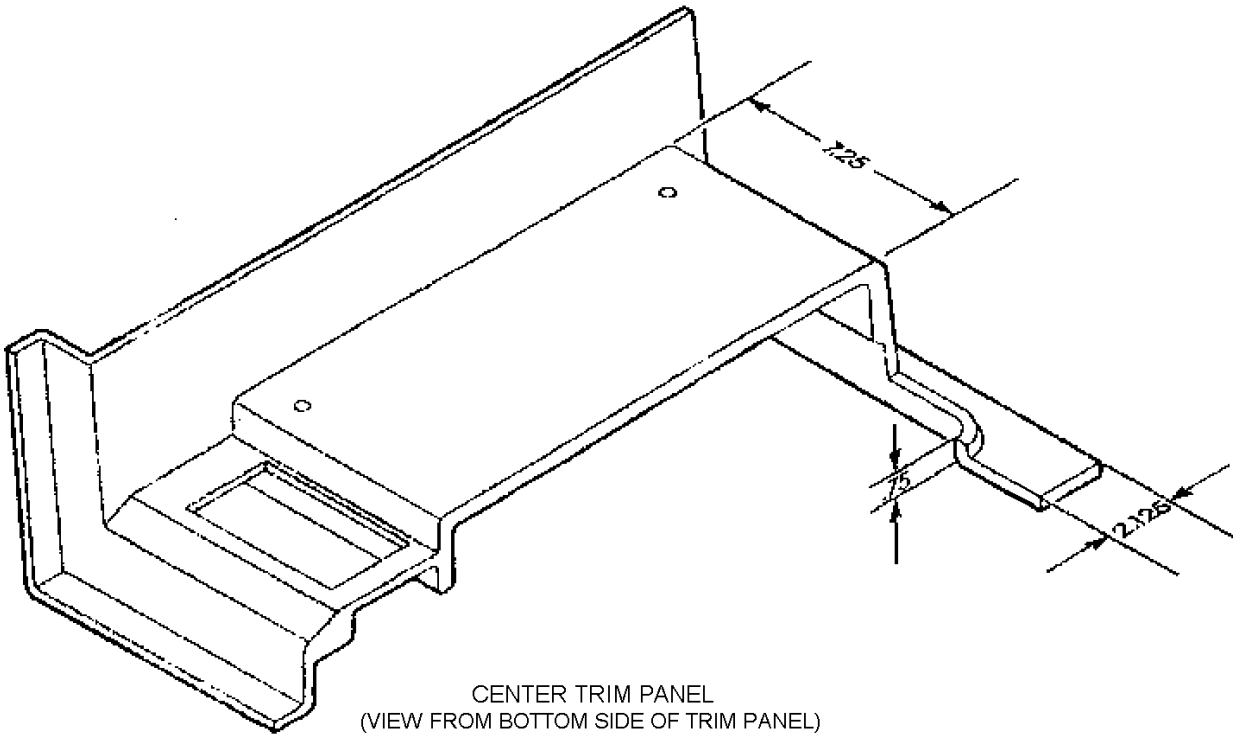

CENTER TRIM PANEL
(VIEW FROM BOTTOM SIDE OF TRIM PANEL)

Center panel cut-out dimensions.

COMPRESSOR:

The compressor mounts to the engine on the location shown in the pictures, on the lower left when facing down the engine toward the fan.

1. The mount bolts to the front left face of the engine, just above the engine mount. Use the 1/2" hardware on the threaded hole and the 7/16" hardware on the top through hole. The 5/8" space may have to be used if there is an engine mount plate in the way of the 1/2" hole. An alignment stud may also have to be ground flush with the mounting surface.
2. The compressor is driven off the open 1/2" pulley groove on the crankshaft assembly of the engine. This pulley is located to the engine side on the harmonic balancer. Use an 17410 belt for this application and tighten the compressor in place. It is important to ensure the oil fill port is oriented 'up'.

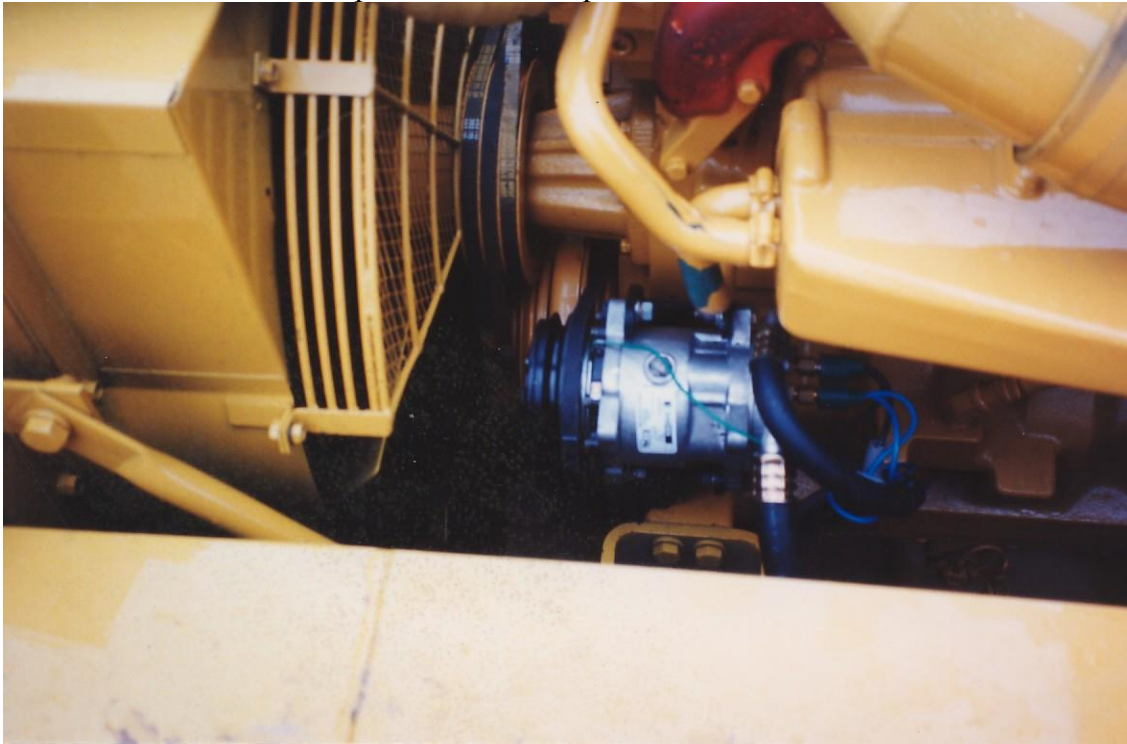

Compressor and mount in place on engine. View from top side of engine compartment.



Compressor in place. View from underneath.

CONDENSER MOUNTING:

The condenser is pre-mounted on its frame and is designed to be mounted on the outside of the radiator assembly,

1. Place the condenser onto the radiator face with the fittings towards the right. Bolt in place using the existing M8 bolt holes and hardware provided in the kit.
2. Mount the drier bracket supplied to the bolt point shown in the pictures. Secure the drier to the bracket using the #48 gear clamps – make sure that the inlet side of the drier is oriented to the radiator.

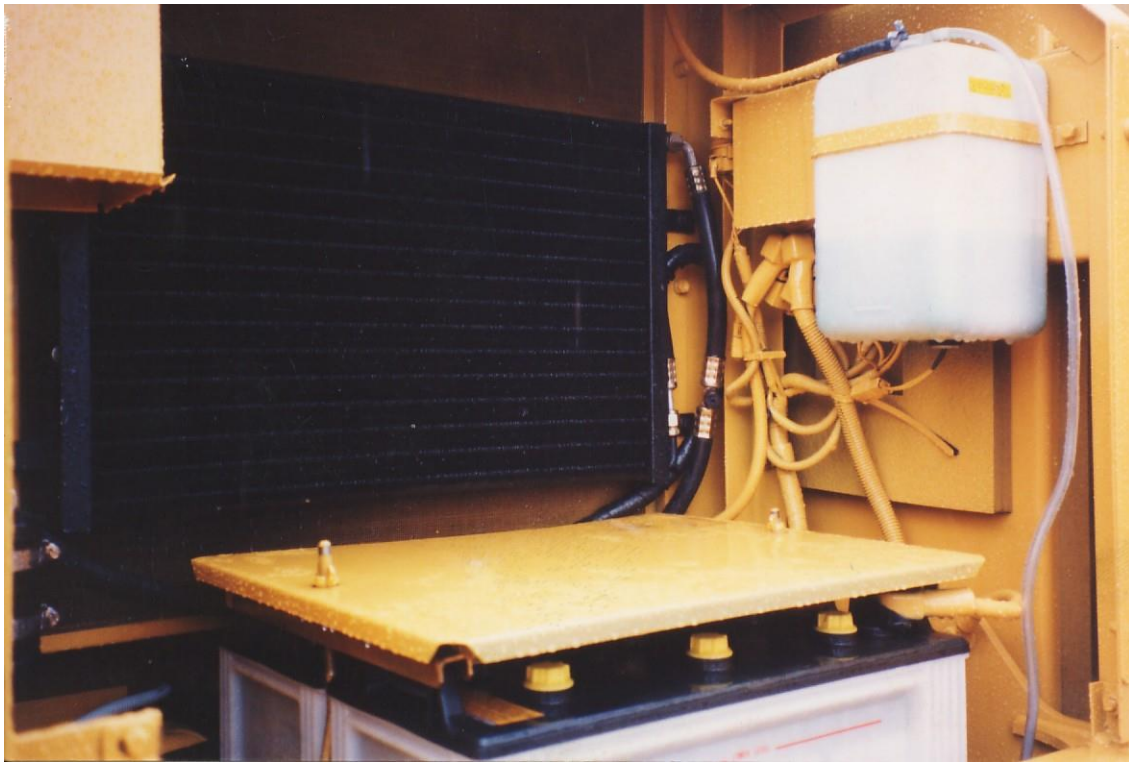

Right side of condenser with bolts in place through flange.

Condenser with drier and hoses in place.



HOSE RUNS:

5/16" Hose Condenser to Drier:

The shorter of the two 5/16" hoses supplied with the kit is designated to run from the condenser to the drier. One pre-crimped 90o fitting is to be connected at the drier and the hose routed to the condenser. Route the hose to the lower fitting on the condenser. Connect the other 90o fitting to the lower fitting on the condenser. Protect the hose with hose wrap at any point that may rub through and secure with hose clamps or cable ties.

5/16" Hose Drier to Evaporator:

The 5/16" hose runs from the drier under the cab of the excavator and up through the large grommet in the floor to connect to the inlet fitting on the expansion valve. The 90o female fitting is connected at the drier and the hose run up into the cab. The 90o male fitting is for the expansion valve at the evaporator.

13/32" Hose Compressor to Condenser:

The 13/32" hose is run from the compressor to the condenser out of the engine compartment alongside the radiator and out to the condenser. The fittings are already crimped in place on the hose and the compressor fitting has the integral charging port. Connect the discharge side rotolock fitting making sure the white nylon seal is properly in place. The binary switch will be on this fitting. Connect the pre-crimped hose end fitting to the rotolock and run out to the condenser. Connect the 90o fitting to the upper fitting on the condenser.

1/2" Hose Compressor to Evaporator

The 1/2" hose runs from the compressor to the evaporator, through the engine compartment, under the cab and up to the evaporator with the 5/16" hose through the large floor grommet. Connect the rotolock fitting on the suction side of the compressor. This fitting will have the 134a charging port on it instead of a 1/4" access port. The fitting at the compressor end of the hose has already been crimped in place. Connect to the rotolock fitting at the compressor and run out under the cab and up to the suction fitting of the evaporator. Connect the 90o male fitting to the evaporator coil suction fitting.

Hose-wrap exposed sections and any places the hoses may rub. Secure using cable ties and clamps where necessary. Use refrigerant oil on the O-rings at the sealing surfaces to ensure a proper seal.

WIRING:

The wiring for the evaporator/blower and compressor assembly is straight forward and easy to install and diagnose problems. All circuits are connected in series.

1. Find the main power feed to the fuse panel. There will often be an open fuse block to draw power from, but, if not, take power from the main feed and use the circuit breaker provided in the kit. Make sure to draw power from an ignition live source that has sufficient power to supply the 20A required by the A/C circuit without problem.
2. Connect the 10ga power wire (red) to the power supply at either the fuse or breaker.
3. Ground the 10ga black wire from the box to an appropriate ground location in the cab.
4. Run the 14ga black clutch wire out with the hoses and connect to the binary switch at the compressor. Connect the wire from the compressor clutch to the open terminal on the binary switch.
5. Test for electrical operation. The clutch will not engage until there is sufficient pressure in the system.
6. Protect the wiring with the split flex loom provided.

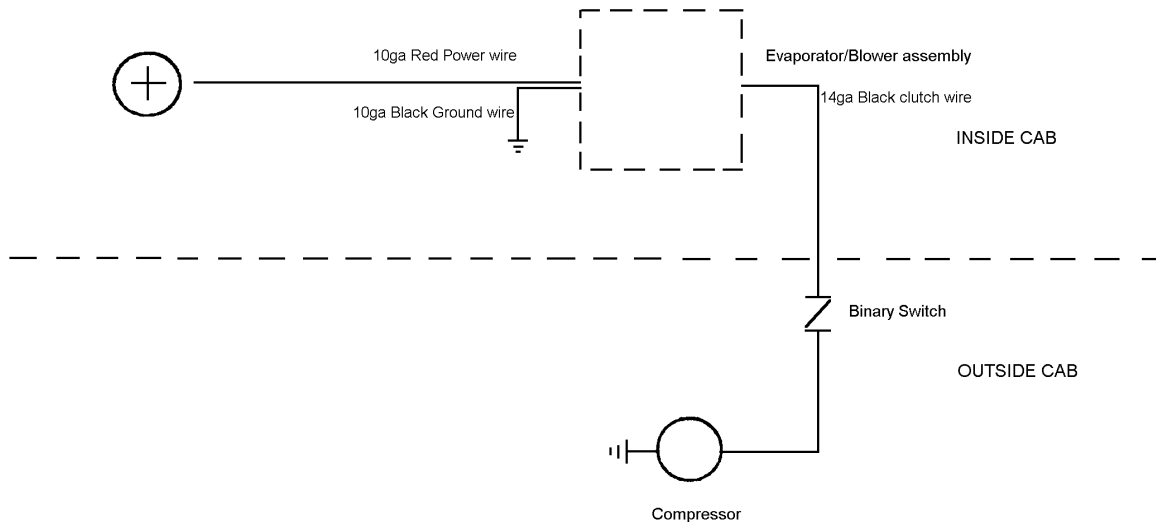

Refrigerant Flow Pattern in a Standard Air Conditioning System

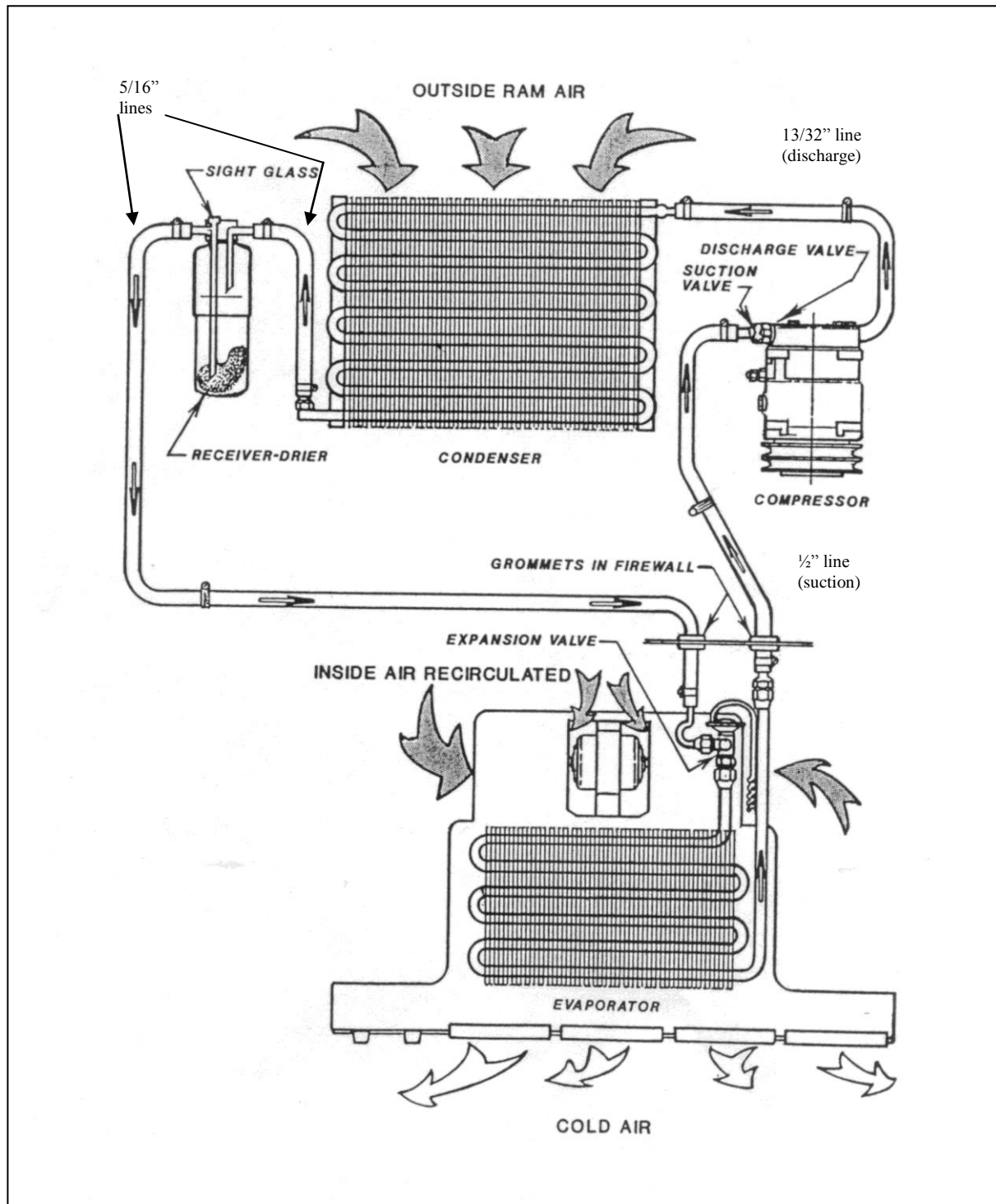

Thermostat Setting Procedures

- 1) Thermostat types
 - a) preset
 - b) adjustable

- a) A preset thermostat is adjusted to its specific cut in and cut out temperatures when manufactured and does not have a rotary adjustment for the operator.
- b) An adjustable or rotary thermostat has been manufactured to a predetermined cut in and cut out temperatures, but it is also operator adjustable to achieve the desired comfort level.

Both types of thermostats can have their factory settings adjusted by turning the setting screws on the body of the thermostat. One body type has the setting screws mounted externally and labeled for direction of rotation. The other body type requires the removal of the plastic end plate to expose the set screw.

- 2) Thermostat probe location: The location of the thermostat probe in an evaporator coil can be very important to achieve the maximum cooling potential of the coil while also preventing coil freeze-up. There is no set location for the thermostat probe to be put that will be optimum for all systems, but several rules of thumb may be followed:
 - a) Insert the probe in the coldest area of the evaporator coil.
 - b) Insert the probe from the top of the coil down, if possible.
 - c) Make sure that at least the last 3" of the thermostat probe are in the coil.

To find the most likely area where the coil is the coldest, consider these factors:

- 1) Direction of air flow through the coil.
 - 2) The coil area likely to have the lowest air flow.
 - 3) The inlet locations of the refrigerant into the coil.
 - 4) The inlet of the hotter outside air into the coil area.
-
- 1) Usually the coldest side of the evaporator coil will be the air outlet side. Often the thermostat probe can be inserted between the last and second last row of tubes.
 - 2) The lower air flow area of the evaporator coil in most systems tends to be near either end of the coil. These areas will be colder
 - 3) The area of the coil that the refrigerant inlet tube(s) occupy should be the coldest part of the coil.
 - 4) If the system is equipped with an outside air intake, where and how that air is brought into the evaporator area can have a large effect on the coil temperature. If all the outside air is piped into the evaporator in one area, that area will be considerably warmer in hot weather.

By looking at all these different factors, the area of an evaporator coil most likely to be the coldest can be determined.

Once the probe is inserted, the A/C system needs to be tested. Run the system to ensure that the thermostat is cycling the compressor off at the appropriate temperature. A core temperature ranging between 25° and 30° F should cause the thermostat to cycle off. The air temperature at the vent outlet closest to the evaporator coil should be between 38° F and 45° F when the compressor cycles off.

If the thermostat doesn't cycle off after a reasonable cool down period, and the air outlet temperature has dropped below 40° F, the cut in and cut out settings should be adjusted until the compressor is cycling on and off regularly. Let the system run for a decent time period (at least 15 min) and then check the evaporator coil for any signs of freezing.

Aeroquip E-Z Clip Assembly Instructions

Step 1. Cut the hose to proper length with an appropriate cutting tool. Aeroquip's hand held hose cutter has been specially designed for cutting all non-wire reinforced hose, such as GH-134 Multi-Refrigerant hose. Be sure the cut is made square to the hose length.

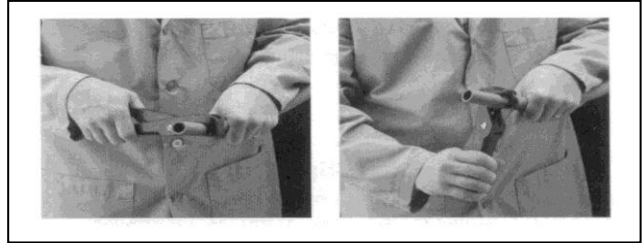

Step 2. Install two proper-sized clips onto the cut end of the hose. Orientation of the clips does not affect the performance of the connection. However, for ease of assembly, both clips should have the same orientation. NOTE: Failure to slide the clips over the hose at this time will require the clips to be stretched over the hose or fitting later. This may permanently damage the clip.

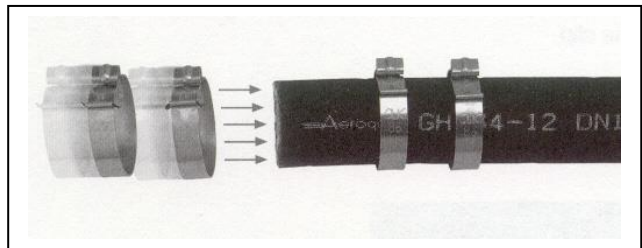

Step 3. Lubricate the nipple with a generous amount of the refrigeration or A/C system's compressor lubricating oil. This MUST be done to lower the force of nipple insertion.

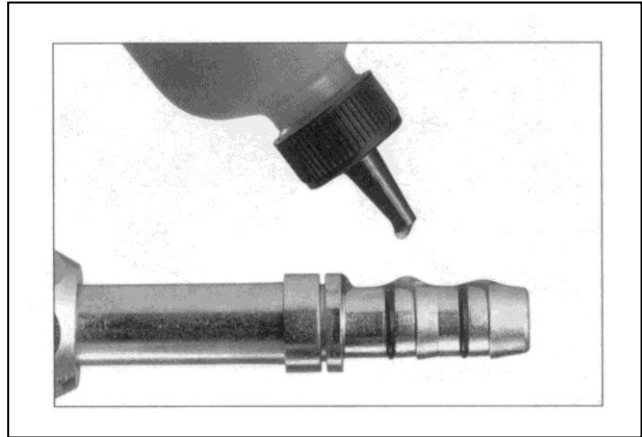

Step 4. Insert the nipple into the hose. To ensure that the nipple is fully inserted, check the gap between the cut end of the hose and the shoulder on the nipple. Care should be taken to avoid kinking or other damage to the hose during nipple insertion.

NOTE: Be sure to wipe excess oil from the nipple and hose.



Step 5. Snap the cage into the groove on the nipple. The arms should extend over the hose length. When the cage has been correctly installed in the cage groove, the cage will be able to rotate in the groove. This step **MUST** be performed to ensure:

1. The clips will be located over the O-rings on the nipple.
2. The connection will be compatible with the connection's pressure rating.

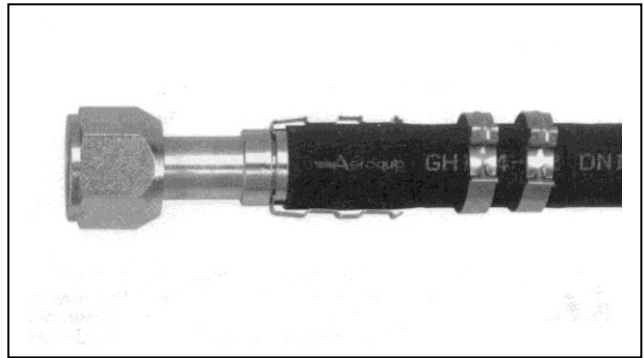

Step 6. Slide the clips over the cage arms and into the channels on each arm.

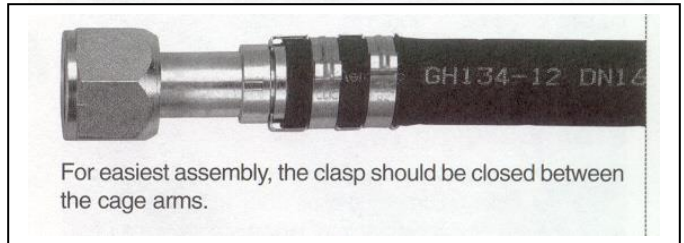
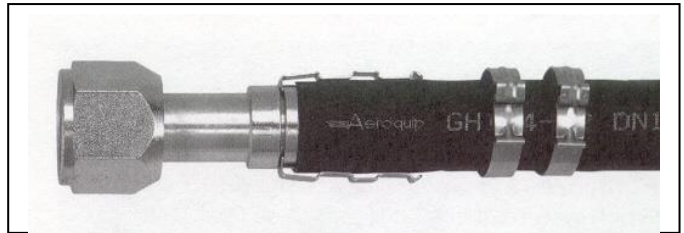

Step 7. Use the pliers to close the clips. The pliers should be positioned squarely on the clip connection points and should remain square during the closing of the clip.

NOTICE: E-Z Clip components should not be reused.

